



Accounts Payable MOCAS Contract Management Overview

Defense Finance and Accounting Service

Mark Miller
Division Chief, MOCAS Contract Management





Distribution of Contract Awards to MOCAS

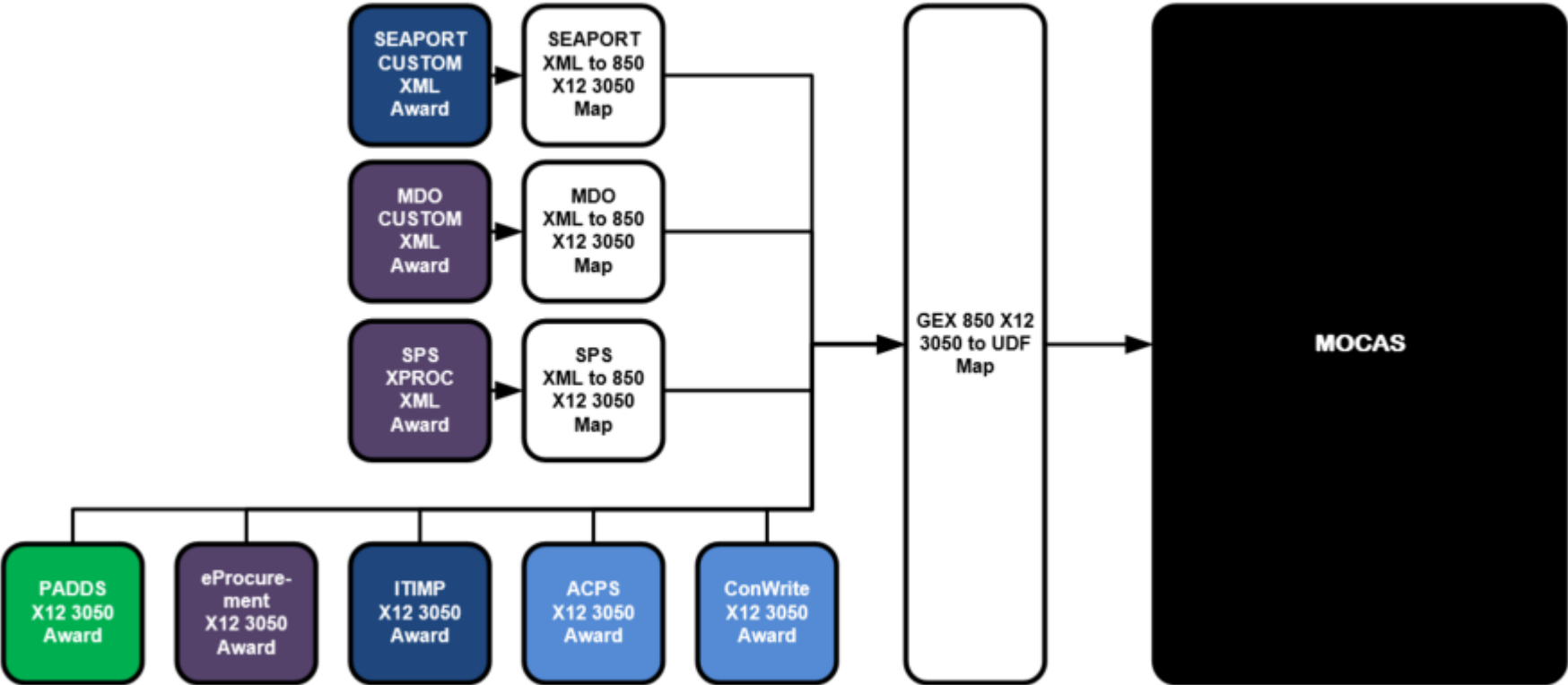

Contract Input Process

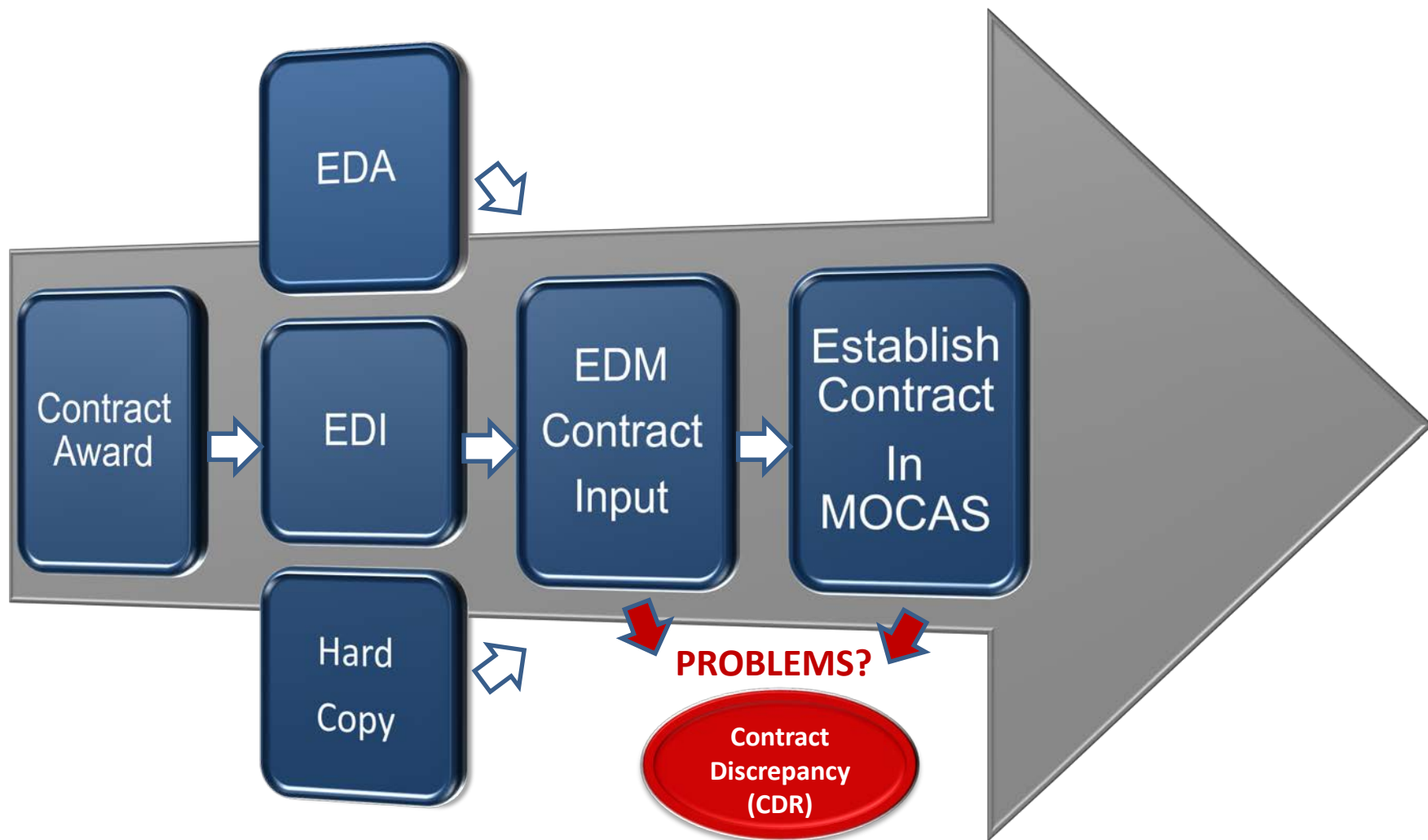

Top Contract Deficiency Reports Root Causes



- ▶ Line of Accounting
 - ✓ Key data not provided
 - ✓ Incorrect FMS Country/Case
- ▶ Sub-CLINS/Informational CLINS
- ▶ Special Payment Instructions not provided
- ▶ Incorrect Pay Office Assignment



Note: Resolution can be delayed due to PCO/ACO failure to register in iRAPT.
your invoice will be coded DCDR1



▶ Invoice submitted has a CLIN cited that is not in MOCAS.

- ✓ Run the report 2x per week
- ✓ Research to determine if the CLIN is valid

- ✓ 000101 should be 0001 on invoice
- ✓ 001001 should be 0010 on invoice

- ✓ Options CLINs are not in MOCAS. Will be input when the option year is exercised

Goal is to have documents processed by day 10, if you invoice prior to that, chances are invoice will be delayed.

Questions

